

# SEAMLESS BEND 22° SDR 11

Łuk formowany 22° SDR 11  
Отвод Гнутый 22° SDR 11

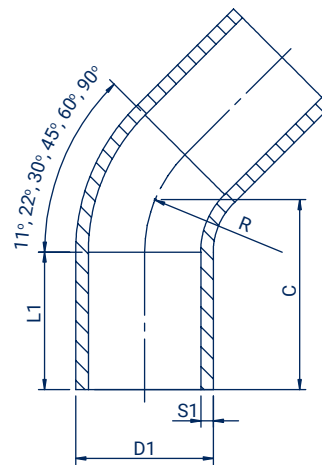

- **application: water and gas** | zastosowanie: woda i gaz |  
применение: вода и газ
- **16 bar water, 10 bar gas** | 16 bar woda, 10 bar gaz |  
16 бар - вода, 10 бар - газ
- **MRS - 10 MPa** | Минимальное сопротивление - 10 МПа
- **installation: electrofusion and spigot welding** | montaż: zgrzewanie elektrooporowe i doczołowe | установка: электросварная и стыковая



Size Wymiar Размер D1 (mm)	Code Kod Код	Angle Kąt Угол	L1 (mm)	C (mm)	S1 (mm)	R (mm)	Weight Waga Вес (kg)	Raw material Tworzywo Материал	Packing Pakowanie Упаковка
32	LU2203211	22	70	98	2,9	48	0,08	PE 100/PE100-RC	-
40	LU2204011	22	75	106	3,7	60	0,10	PE 100/PE100-RC	-
50	LU2205011	22	80	130	4,6	75	0,20	PE 100/PE100-RC	-
63	LU2206311	22	90	150	5,8	94,5	0,35	PE 100/PE100-RC	-
75	LU2207511	22	100	155	6,8	112,5	0,58	PE 100/PE100-RC	-
90	LU2209011	22	150	350	8,2	135	1,42	PE 100/PE100-RC	-
110	LU2211011	22	150	330	10	165	2,07	PE 100/PE100-RC	-
125	LU2212511	22	150	380	11,4	188	3,06	PE 100/PE100-RC	-
140	LU2214011	22	150	395	12,7	210	3,96	PE 100/PE100-RC	-
160	LU2216011	22	150	420	14,6	480	5,66	PE 100/PE100-RC	-
180	LU2218011	22	150	450	16,4	270	7,49	PE 100/PE100-RC	-
200	LU2220011	22	150	480	18,2	300	9,88	PE 100/PE100-RC	-
225	LU2222511	22	150	510	20,5	338	13,36	PE 100/PE100-RC	-
250	LU2225011	22	250	550	22,7	375	17,66	PE 100/PE100-RC	-
280	LU2228011	22	250	400	25,4	420	16,30	PE 100/PE100-RC	-
315	LU2231511	22	250	460	28,6	472,5	21,85	PE 100/PE100-RC	-
355	LU2235511	22	300	540	32,2	532,5	37,00	PE 100/PE100-RC	-
400	LU2240011	22	300	560	36,3	600	45,90	PE 100/PE100-RC	-
450	LU2245011	22	300	580	40,9	675	60,20	PE 100/PE100-RC	-
500	LU2250011	22	350	650	45,4	750	83,30	PE 100/PE100-RC	-
560	LU2256011	22	350	680	50,8	840	108,60	PE 100/PE100-RC	-
630	LU2263011	22	350	730	57,2	945	171,00	PE 100/PE100-RC	-

