

# SEAMLESS BEND 11° SDR 11

Łuk formowany 11° SDR 11  
Отвод Гнутый 11° SDR 11

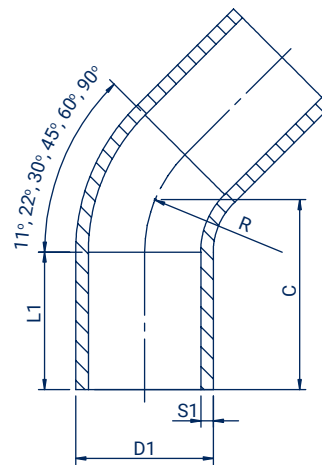

- **application: water and gas** | zastosowanie: woda i gaz |  
применение: вода и газ
- **16 bar water, 10 bar gas** | 16 bar woda, 10 bar gaz |  
16 бар - вода, 10 бар - газ
- **MRS - 10 MPa** | Минимальное сопротивление - 10 МПа
- **installation: electrofusion and spigot welding** | montaż: zgrzewanie elektrooporowe i doczołowe | установка: электросварная и стыковая



Size Wymiar Размер D1 (mm)	Code Kod Код	Angle Kąt Угол	L1 (mm)	C (mm)	S1 (mm)	R (mm)	Weight Waga Вес (kg)	Raw material Tworzywo Материал	Packing Pakowanie Упаковка
32	LU1103211	11	70	98	2,9	48	0,08	PE 100/PE100-RC	-
40	LU1104011	11	75	106	3,7	68	0,12	PE 100/PE100-RC	-
50	LU1105011	11	80	130	4,6	75	0,22	PE 100/PE100-RC	-
63	LU1106311	11	90	150	5,8	94,5	0,35	PE 100/PE100-RC	-
75	LU1107511	11	100	155	6,8	112,5	0,52	PE 100/PE100-RC	-
90	LU1109011	11	150	350	8,2	135	1,42	PE 100/PE100-RC	-
110	LU1111011	11	150	330	10	165	2,14	PE 100/PE100-RC	-
125	LU1112511	11	150	380	11,4	188	3,38	PE 100/PE100-RC	-
140	LU1114011	11	150	395	12,7	210	3,96	PE 100/PE100-RC	-
160	LU1116011	11	150	415	14,6	480	5,54	PE 100/PE100-RC	-
180	LU1118011	11	150	450	16,4	270	7,49	PE 100/PE100-RC	-
200	LU1120011	11	150	480	18,2	300	9,88	PE 100/PE100-RC	-
225	LU1122511	11	150	510	20,5	338	13,36	PE 100/PE100-RC	-
250	LU1125011	11	250	540	22,7	375	17,66	PE 100/PE100-RC	-
280	LU1128011	11	250	400	25,4	420	16,30	PE 100/PE100-RC	-
315	LU1131511	11	250	460	28,6	472,5	21,85	PE 100/PE100-RC	-
355	LU1135511	11	300	540	32,2	532,5	41,00	PE 100/PE100-RC	-
400	LU1140011	11	300	560	36,3	600	45,90	PE 100/PE100-RC	-
450	LU1145011	11	300	580	40,9	675	60,20	PE 100/PE100-RC	-
500	LU1150011	11	350	650	45,4	750	83,30	PE 100/PE100-RC	-
560	LU1156011	11	350	680	50,8	840	108,60	PE 100/PE100-RC	-
630	LU1163011	11	350	730	57,2	945	148,30	PE 100/PE100-RC	-

